

# Bulroc CDS 240R

## Concentric Drilling System

Drilled Hole diameter 296mm

Casing Size 273mm O/D x 260mm I/D

# CDS 240R

## Concentric Drilling System

The CDS 240R is a concentric overburden drilling system designed for the continuous casing of a 296mm diameter hole, through loose overburden materials down into solid bedrock.

The CDS 240R comprises the Driver, which is available for drilling with most 8" hammers, together with a replaceable Ring Bit and three replaceable Segments.

At the start of the drilling operation, the Segments are in the closed position to allow the system to pass through the casing shoe. When drilling commences, the Segments should be in the open position ready to drill a hole size of 296mm. When the hole is completed the system can be withdrawn through the casing by reverse rotating, effectively closing the segments within the diameter of the body.

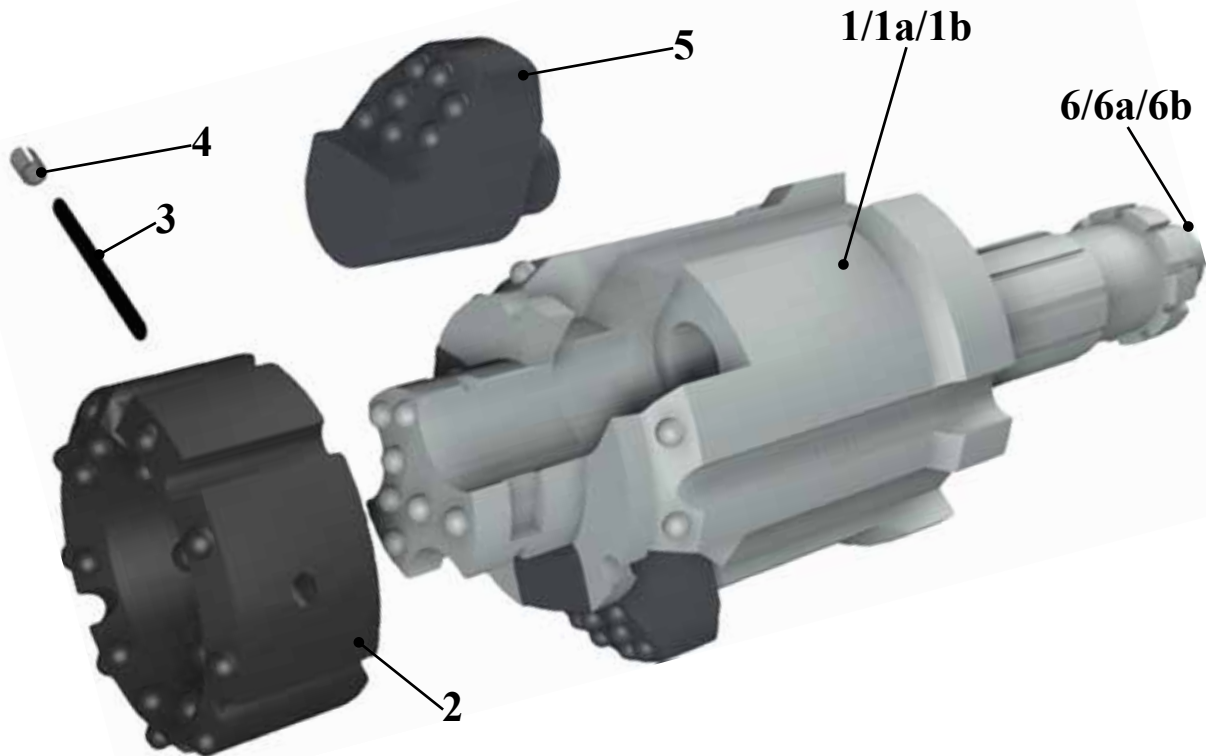

SPECIFICATIONS	
Description	Metric
Major Body Diameter	256 mm
Length (less Foot valve DHD 380)	745 mm
Length (less Foot valve SD8)	740 mm
Length (less Foot valve QL80)	720 mm
System Open	296 mm
Casing Size	273mm OD x 260mm ID
Total Weight DHD 380	136 Kg
Total Weight SD8	135 Kg
Total Weight QL80	136 Kg

COMPONENT PARTS		
Ref	Description	Part No.
1	Driver (DHD380)	CDS240DH094R
1a	Driver (SD8)	CDS240DH045R
1b	Driver (QL80)	CDS240DH108R
2	Ring Bit	CDS240RRING
3	Solid Retaining Pin	CDS240RRP
4	Seloc Pin Set	CDS240RSP
5	Segments (3)	CDS240RSEG
6	Foot Valve (DHD380)	BBF094
6a	Foot Valve (SD8)	BBF045
6b	Foot Valve (QL80)	BBF108
	Complete System(DHD380)	CDS240094R
	Complete System(SD8)	CDS240045R
	Complete System(QL80)	CDS240108R