

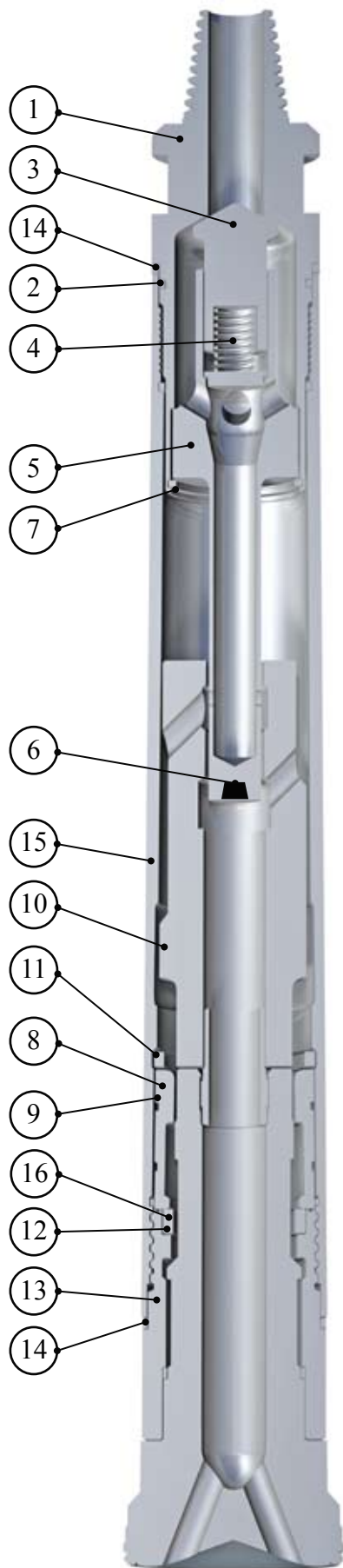

**Hyper 66DH / QL60
Hammer**



Hyper 66DH / QL60 (Deep Hole) Hammer 152mm (6") - 216mm (8½") dia. Holes

The Hyper 66DH is a valveless DTH Hammer specifically designed to operate efficiently at depths and overcome high heads of water. The combined plastic control tube, diverter and check valve minimises the number of component parts, reducing the overall length of the hammer for ease of handling.

The Hyper 66DH is supplied as standard with a 3½" API reg. pin, backhead and a chuck to accept button bits with Ingersoll Rand QL 60 shanks.

Alternatively, the Hyper 66DH can also be supplied with chucks to suit most other major types of button bits including IR DHD 360.

Component Parts

| Ref | Description | Part Number | Qty |
|-----|------------------------|---------------|-----|
| 1 | Backhead | HSH66DH3803M | 1 |
| 2 | Backhead 'O' Ring | HSH6114 | 1 |
| 3 | Check Valve | IPRCV04 | 1 |
| 4 | Check Valve Spring | IPRCVS04 | 1 |
| 5 | Control Tube | HSH66DH30 | 1 |
| 6 | Solid Choke Set | HSH66DH19 | 1 |
| 7 | Circlip | HSH66DH22 | 1 |
| 8 | Bush | HSH66DH86 | 1 |
| 9 | Bush 'O' Ring | HSH6386A | 2 |
| 10 | Piston | HSH66DH03099 | 1 |
| 11 | Piston Retaining Ring | HSH6132 | 1 |
| 12 | Bit Retaining Ring | HSH66DH37099 | 1 |
| 13 | Chuck | HSH66DH35099 | 1 |
| 14 | Breakout Washer | HSH6326 | 2 |
| 15 | Wearsleeve | HSH66DH0099 | 1 |
| 16 | Bit Retaining 'O' Ring | HSH66DH37A099 | 1 |
| | Complete Hammer | BR66DH02 | |

Hammer Specification

| | Imperial | Metric |
|-------------------|----------|-----------|
| Weight (less bit) | 219 lbs | 100 Kgs |
| Length (less bit) | 40.90" | 1039 mm |
| Outside dia. | 5.620" | 142.75 mm |
| Piston weight | 43.5 lbs | 20 Kg |
| Stroke | 4.25" | 108 mm |

Air Consumption

| PSI | BAR | C.F.M | Cu. Mtr / min |
|-----|-------|-------|---------------|
| 150 | 10.30 | 296 | 8.39 |
| 200 | 13.80 | 456 | 12.92 |
| 250 | 17.20 | 637 | 18.05 |
| 300 | 20.70 | 838 | 23.73 |
| 350 | 24.1 | 1058 | 29.98 |